

Box Bolt®

A KEE SAFETY PRODUCT

SAFE STEELWORK CONNECTIONS

Curtain Walling & Bolted Glass Facades



- LLOYD'S REGISTER & DIBT APPROVED FIXINGS
- GUARANTEED SAFE WORKING LOADS
- 5 TO 1 FACTOR OF SAFETY



Box Bolt®

A KEE SAFETY PRODUCT

BoxBolt blind steelwork fixings offer Designers and Installers a range of approved and tested bolts suitable for fixing structural glazing spider and curtain wall brackets directly onto Steel Hollow Section Structures. The safety of the curtain wall installation makes it critical that care is taken to select suitable fixings that provide a guaranteed safe working load. Installations need to accommodate a wide variance in loadings, these alter with the individual weight of the curtain walling together with the design wind load, and the **BoxBolt** range provides effective solutions from small low rise buildings to multi-storey mega structures.



The complete fixing is inserted into a preformed hole in the spider or curtain wall brackets and ultimately into the main steel structure, the grade 8.8 bolt is then simply tightened to the recommended torque which in turn expands the fins of the main body to complete the connection.

Where the brackets are visible through the glass, in particular Spider brackets the overall aesthetics of the fixing can be significantly improved by choosing our Button Head, Socket Head Cap or Countersunk types as the adjacent illustrations show.

BoxBolt fixings have been extensively tested, and are certified by Lloyds Type Register and Deutches Institut fur Bautechnik for use within Safe Working Loads for Tensile and Shear.

BoxBolt fixings are manufactured in three different lengths that facilitate the fixing of an extensive range of Bracket or Spider supports onto Structural Hollow Section steelwork to a total maximum clamping range of 102mm.

SCI publication 101 - Curtain Wall Connections to Steel Frames, recommends consideration be given for corrosion resistant fixings. **BoxBolt** fixings are supplied in Hot dip spun Galvanised to BS EN ISO 1461 and Stainless Steel to BS EN 10088 grade 1.4401 in addition to a standard zinc plated option.

BoxBolt fixings are very easy to install and do not require special tools.

BoxBolt fixings are constructed from three separate parts:

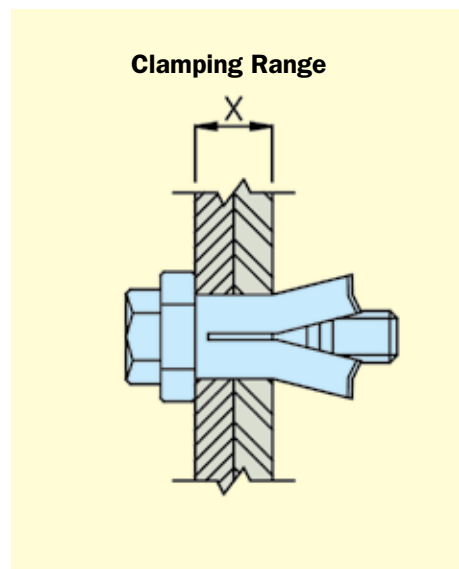
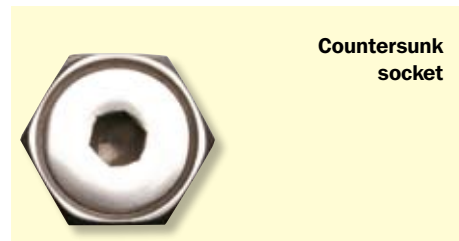
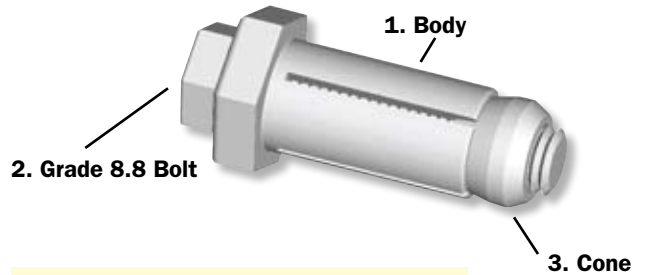

Safe Fixing Solutions

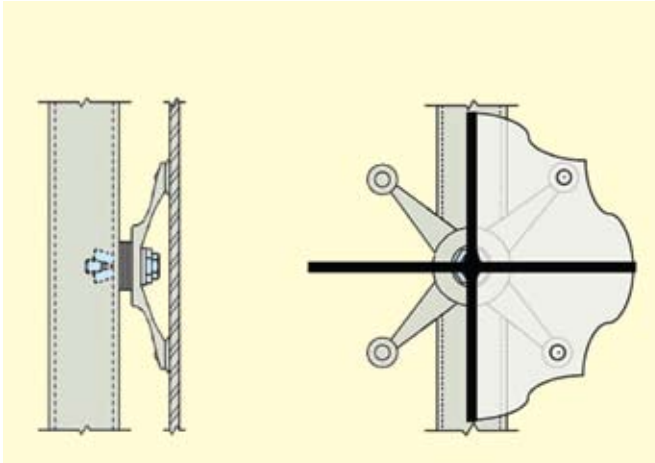

STRUCTURAL GLAZING SPIDER BRACKET FIXED TO CIRCULAR HOLLOW SECTIONS OR RECTANGULAR HOLLOW SECTIONS.

Spiders are generally cast, profiled or machined metal brackets with one, two, three or four arms together with a central hole to accommodate a **BoxBolt** fixing direct into the mainframe steel structure.

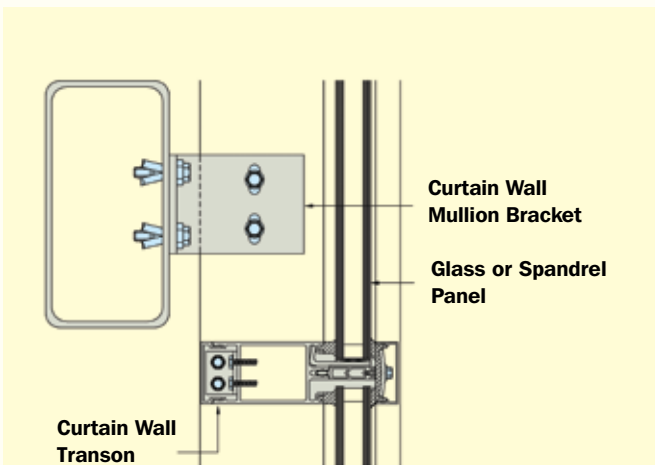

CURTAIN WALL MULLION BRACKET FIXED TO SQUARE OR RECTANGULAR HOLLOW SECTIONS.

Angle brackets provide a simple form of fixing, these can be fabricated to suit individual construction requirements. **BoxBolt** fixings offer erectors flexibility with multi directional on site adjustment.

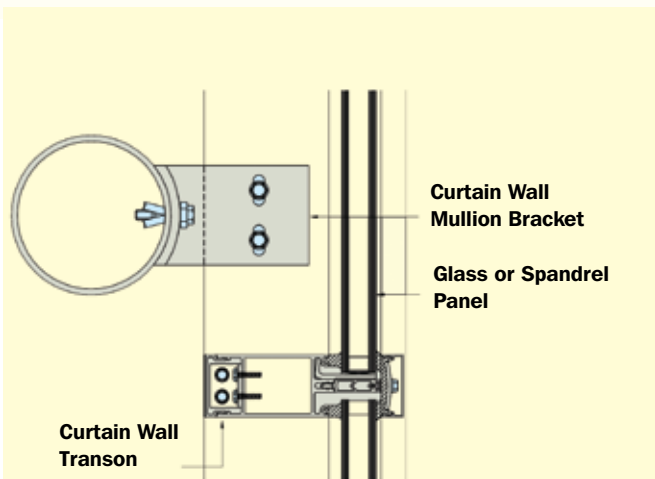

CURTAIN WALL MULLION BRACKET FIXED TO CIRCULAR HOLLOW SECTIONS.

Fabricated brackets provide a neat solution when fixing to Circular Hollow Section, these are fabricated to suit individual construction requirements. **BoxBolt** fixings offer erectors flexibility with multi directional on site adjustment.

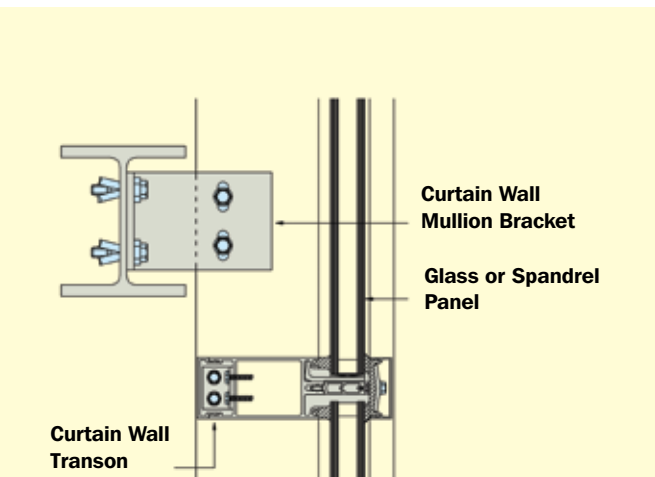

CURTAIN WALL MULLION BRACKET FIXED TO BEAMS, COLUMNS OR CHANNELS

Angle brackets provide a simple form of fixing, these can be fabricated to suit individual construction requirements. **BoxBolt** fixings offer erectors ease of fixing when access is limited and flexibility with multi directional on site adjustment.

Wind Loading

Before consideration can be given to the choice of fixings suitable for a particular curtain walling installation, **BS6399 part 2:1997 Code of practice for wind loads** should be consulted to determine the probable gust peak wind loads using either (a) the standard method or (b) the directional method. There are many factors that influence wind load design including; site location, altitude, ground roughness, seasonal and probability factors all of which must be calculated by a suitably qualified Engineer. Once the magnitude of wind loads has been determined the size and frequency of fixings and brackets can then be designed.

BoxBolt Safe Working Loads

The table below provides safe working loads in both tensile and shear for single bolt connections. All safe working loads contain a **5:1 factor of safety**.

Part Number & description			Dimensional information				Load information				
BoxBolt Size	Product code	Size	Setscrew length (mm)	Clamping range (dim x) Min Max		Hole size (ø c)	Bolt Dia.	Thickness of material being connected to	Safe Working loads (kn) Tensile Shear		Torque (Nm)
M06	BQ1Z06*	1	45	3	29	11 +1.0,-0.25	M06	3.0	2.2	5	19
M08	BQ1_08	1	50	3	26	14 +1.0,-0.25	M08	5.0	2.7	7	25
	BQ2_08	2	70	12	46			6.3 or 8.0	4.5		
	BQ3_08	3	90	24	66			10.0 or 12.5	6		
M10	BQ1_10	1	50	3	23	18 +1.0,-0.25	M10	5.0	4.5	13	45
	BQ2_10	2	70	15	43			6.3	8.4		
	BQ3_10	3	90	30	63			10.0 or 12.5	11.5		
M12	BQ1_12	1	55	3	25	20 +1.0,-0.25	M12	5.0	4.5	15	80
	BQ2_12	2	80	18	50			6.3	7.8		
	BQ3_12	3	100	36	70			8.0	13.1		
								10.0 or 12.5	15.4		
M16	BQ1_16	1	75	3	35	26 +2.0,-0.25	M16	5.0	6.4	35	190
	BQ2_16	2	100	24	60			6.3	8.2		
	BQ3_16	3	120	48	80			8.0	13.9		
								10.0	23.7		
								12.5	31		
M20	BQ1_20	1	100	3	42	33 +2.0,-0.25	M20	6.3	8	40	300
	BQ2_20	2	120	30	72			8.0	15.3		
	BQ3_20	3	150	60	102			10.0	28.4		
								12.5	43.7		

For further information or advice please forward your enquiry to the contact details shown below.



Kee Safety Ltd.
Cradley Business Park
Overend Road
Cradley Heath
West Midlands
B64 7DW

Tel: +44 (0) 1384 632386
Fax: +44 (0) 1384 632384

Email: sales@boxbolt.com
web: www.keesafety.com/boxbolt